

LUDWIG PANI
COMPANY FOR STAGE LIGHTING AND PROJECTION



GREY SCALE SHUTTER

G405/PCS



16.Feb.1993

OPERATIONS MANUAL

CONTENTS

	Page
1. DESCRIPTION AND OPERATING PRINCIPLE	1
2. MECHANICAL ASSEMBLY	1
2.1 Dimension Drawing	2
2.2 Position Drawing Shutter	3
2.3 Position Drawing Control Box	4
3. ELECTRICAL ASSEMBLY	5
3.1 Control Box	5
3.1.1 Processor Card	5
3.1.2 Motor Control Card	6
3.1.3 Operation (Service) Print	6
3.1.4 AC/DC Converter	6
3.1.5 Power Supply	6
3.1.6 Display	7
3.2 The Shutter	7
4. COMPONENTS AS DELIVERED	7
4.1 Accessories	7
5. OPERATING INSTRUCTIONS	8
5.1 Mounting the Unit on the Projector	8
5.1.1 Changing the Extension Rails	8
5.2 Electrical Hook-Up	8
5.2.1 Internal Control	8
5.2.2 External Control	9
5.3 Curve Selector Switch Set-Up	10
5.4 Replacing the Grey scale Wedges	13
6. ADJUSTMENT PROCEDURE	14
6.1 Shutter	14
6.2 Control Box	15
6.2.1 Adjustment of the AC/DC Converter	15
6.2.2 Adjustment of the Processor Card	16
7. GENERAL TECHNICAL DATA	17
8. SPARE PARTS LIST	18
8.1 Shutter	18
8.2 Control Box	19
9. WIRING DIAGRAM	20

1. DESCRIPTION AND OPERATING PRINCIPLE

The Grey Scale Shutter has been developed out of the need to control the intensity of the HMI light source in the same manner as dimming a halogen lamp. The positioning of two grey scale wedges (205 x 220mm) is accomplished by means of a processor controlled stepper motor.

Adjustment of the non linear grey scale wedge travel to the eye-linearity is achieved with tabulated positioning of a stepper motor. With this positioning table, the control voltage of the lighting control console is adapted to provide a specifically corrected grey scale positioning, which produces visually linear light intensity control.

By jerks of the grey scale wedges and associated flickering of the projected image is eliminated through the high resolution of the stepper motor.

The vacuum deposition process for the neutral density coating guaranties uniform color temperature, wide dimming range, even image sharpness and 100% consistency in replacement glass.

2. MECHANICAL ASSEMBLY

The System consists of a singular dimming shutter and an associated control box, both in half-shell enclosures. Mounted in the shutter is the stepper motor. This allows the two grey scale wedges to move opposite on another on a timing belt. In addition, the shutter housing includes the positioning and reset device as well as a directional blower for cooling the glass. A protective shield is provided to prevent damage during transport. Mounting is accomplished by means of a pair of guide tubes and mounting brackets on the projektor. The control box may be clamped to the projektor.

**see also assembly instruction,
attached at the end of the document**

2.1 DIMENSION DRAWING

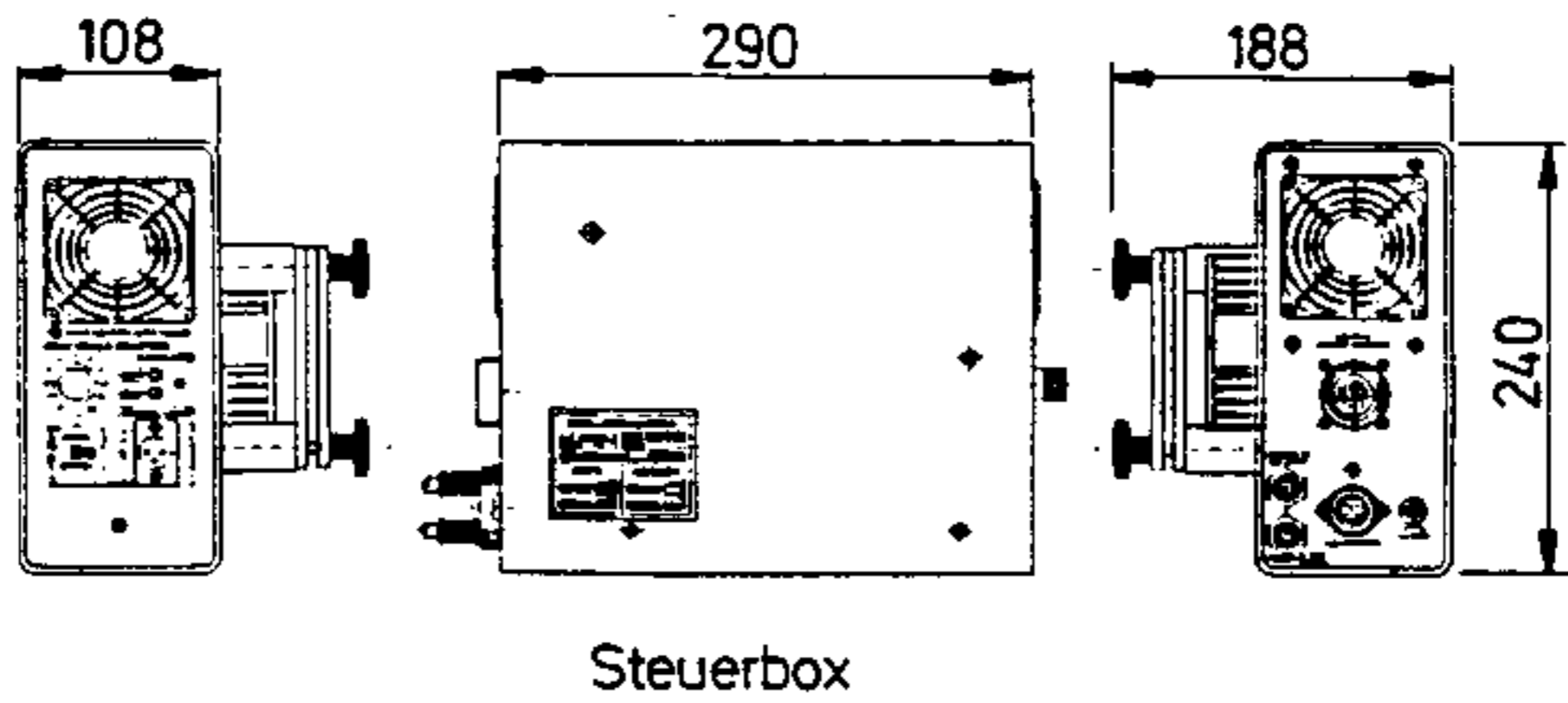
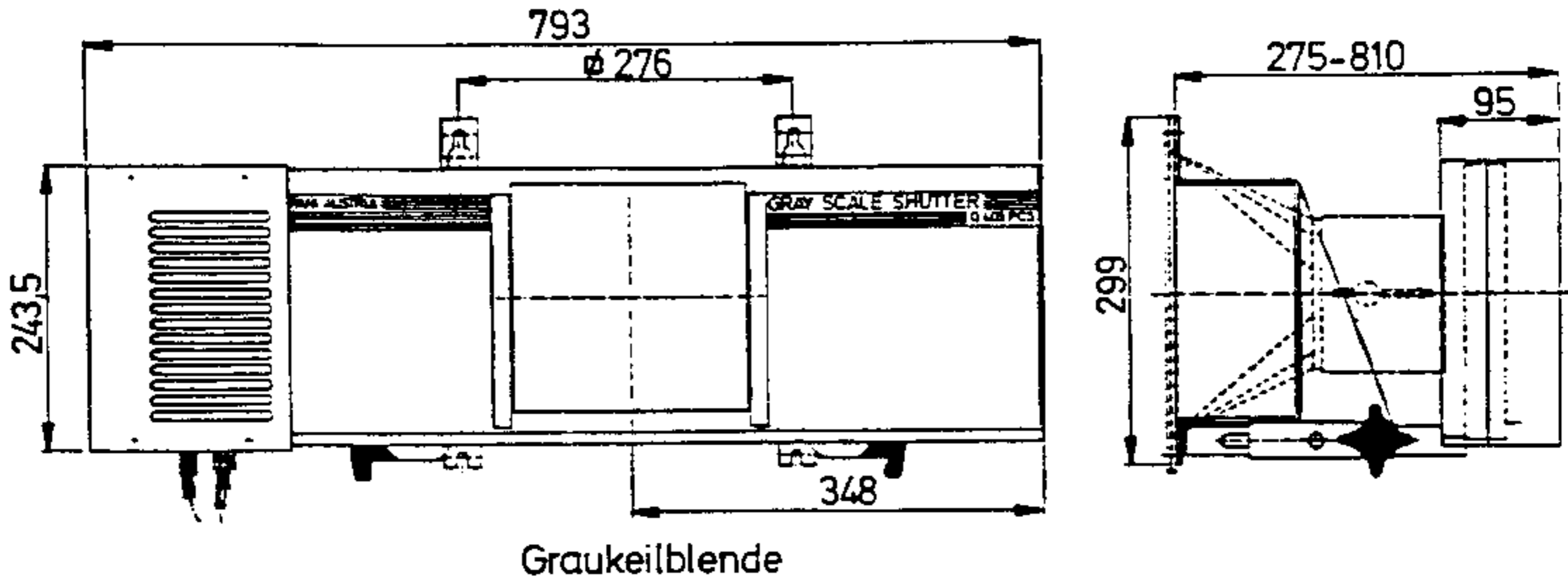

2.2 POSITION DRAWING: SHUTTER

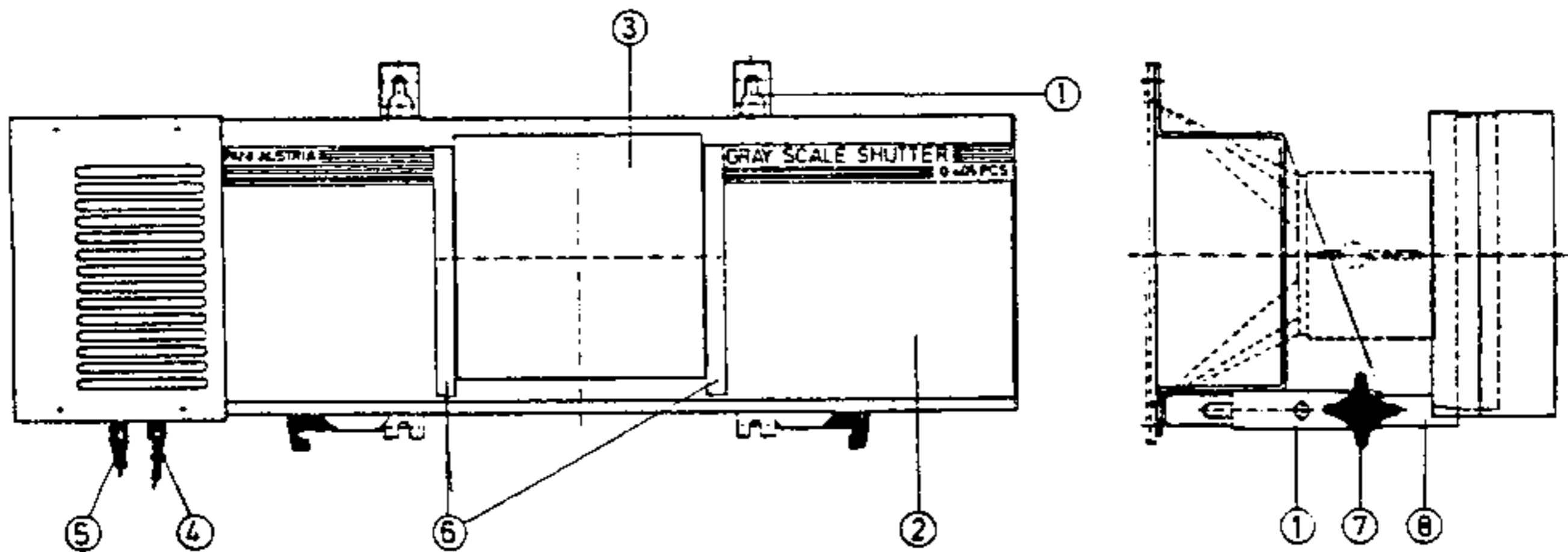

- 1 - Mounting brackets
- 2 - Shutter Cover
- 3 - Grey Scale Wedges
- 4 - Ventilator Power Cable
- 5 - Sleeve with Control Conductors
- 6 - Insert for Protective Cover or Filter Frames
- 7 - Grip Clamp for Shutter Extension Adjustment
- 8 - Guide Rails

2.3 POSITION DRAWING: CONTROL BOX

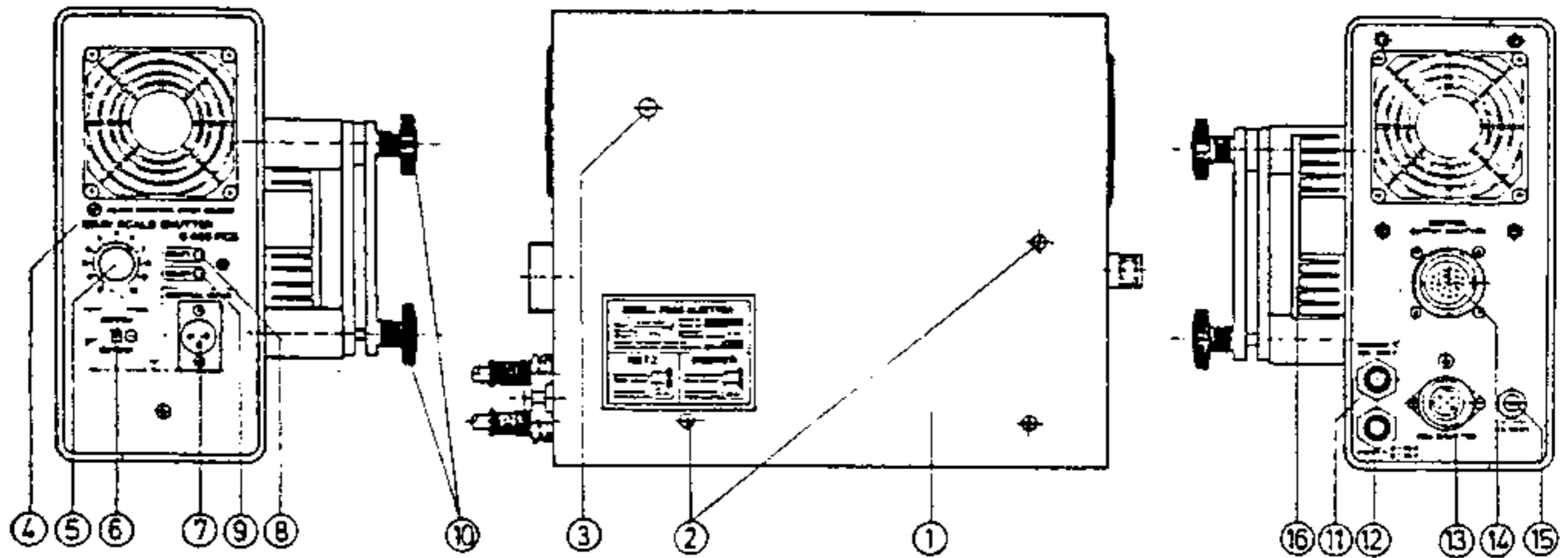

- 1 - Housing Cover
- 2 - Cover Mounting Screws
- 3 - Internal Adjustment "INTERN"
- 4 - External Adjustment "EXTERN"
- 5 - Potentiometer for Local "INTERN" Adjustment
- 6 - Mode Switch for Internal / External Control
- 7 - Control Voltage Input for +/- 0 - 10 DC
- 8 - LED Reset Indicator
- 9 - LED Ready Indicator
- 10 - Mounting Clamp
- 11 - Dimmer Voltage Input 0 - 120/220-240 VAC
- 12 - Source Voltage (Main Power) 110-120/220-240 VAC
- 13 - Fan Power (shutter)
- 14 - Control Connector (Shutter)
- 15 - Main Fuse 4Af
- 16 - Heat Sink for dummy load

3. ELECTRICAL ASSEMBLY

The signal connection between the control box and the shutter is provided by a 14 pole cable supplied with a SCHALTBAU-connector. The shutter ventilator is supplied with power from the control box. The control unit itself receives power from the projector via a 4 pin Amphenol connector.

3.1 CONTROL BOX

All operation and control elements as well as external control inputs are placed here. The control box is modular, which allows individual cards to be easily removed. The following cards are included in the unit.

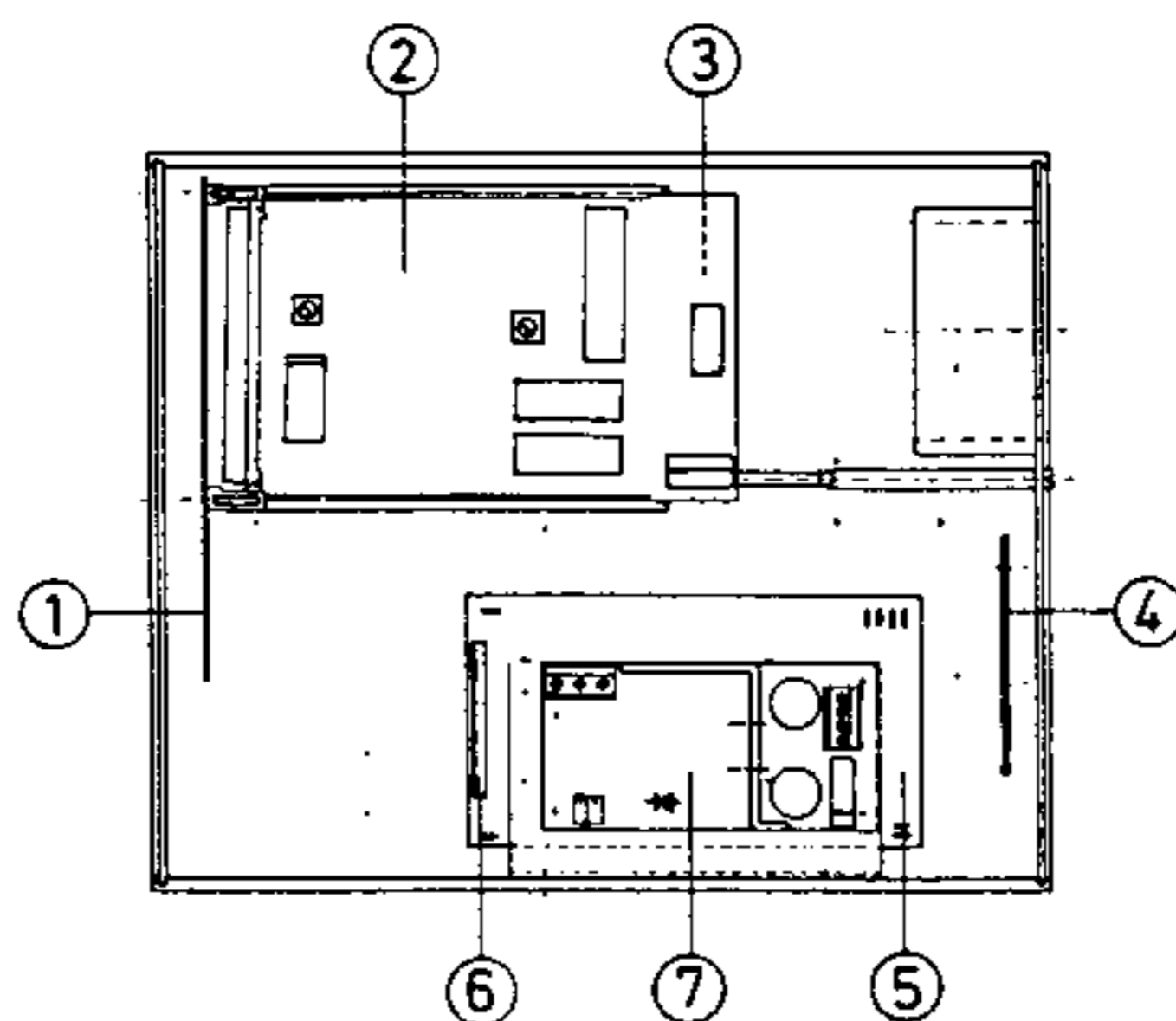

- 1 - Mother Board
- 2 - Processor Card
- 3 - Motor Control Card
- 4 - Operation (Service) Card
- 5 - Power Section
- 6 - Switcher 110/220 VAC
- 7 - AC/DC Converter

3.1.1 PROCESSOR CARD

The unit is supplied with an INTEL Microprocessor type 80C31 and an EPROM 27C256 for the program.

The three standard correction curves for choice of grey scale travel are configured in this EPROM. The specific curve is selected by means of a hook switch (see also page 11).

3.1.2 MOTOR CONTROL CARD

The micro step control (DIVI-STEP) is responsible for the drive of the 5 phase stepper motor. The maximum resolution of 10,000 steps per revolution translates to an angle of 0.036 degrees per step. This card consists of the power section - 5 constant flow limit steps - and the logic switching with analog outputs to the control of the limit steps.

3.1.3 OPERATION (SERVICE) PRINT

This card supplies control voltage to the processor card. With electronic lighting control consoles a control voltage of normally 0 to 10 volts DC is transferred through the multiplexing and conditioning of 8-bit information. This results, especially with long fades, in imperceptible "light steps". With a special integrated circuit, which can be found on this print, equal movement of the grey scale wedges is created without fluctuation of dynamic.

Control voltage may be + or - 0 - 10VDC. Polarity switching is not necessary.

3.1.4 AC/DC CONVERTER

This transforms regulated output voltage from lighting dimmers to a control voltage of 0 - 10 VDC. With this transformation becomes control voltage through the angle of a clipped sinus curve (phase converter). With this method, voltage fluctuation has no influence on the conditioned control voltage, i.e. on the travel of the glass plates. Connection to dimmer circuit is provided by a 3 meter long cable with a "Schuko" connector. Trigger current for SCR (Thyristor) dimmers is produced by a dummy load, the heat loading of which is dissipated by a heat sink mounted on the exterior of the control box.

3.1.5 POWER SUPPLY

The power supply delivers voltage to the motor (36VDC) and supplies voltage for all of the electronics. By rotating the voltage select card on the power supply 180 degrees, a mains voltage (110-120/220-240 VAC) may be selected. The unit is protected by a 4Af - 5 x 20mm fuse.

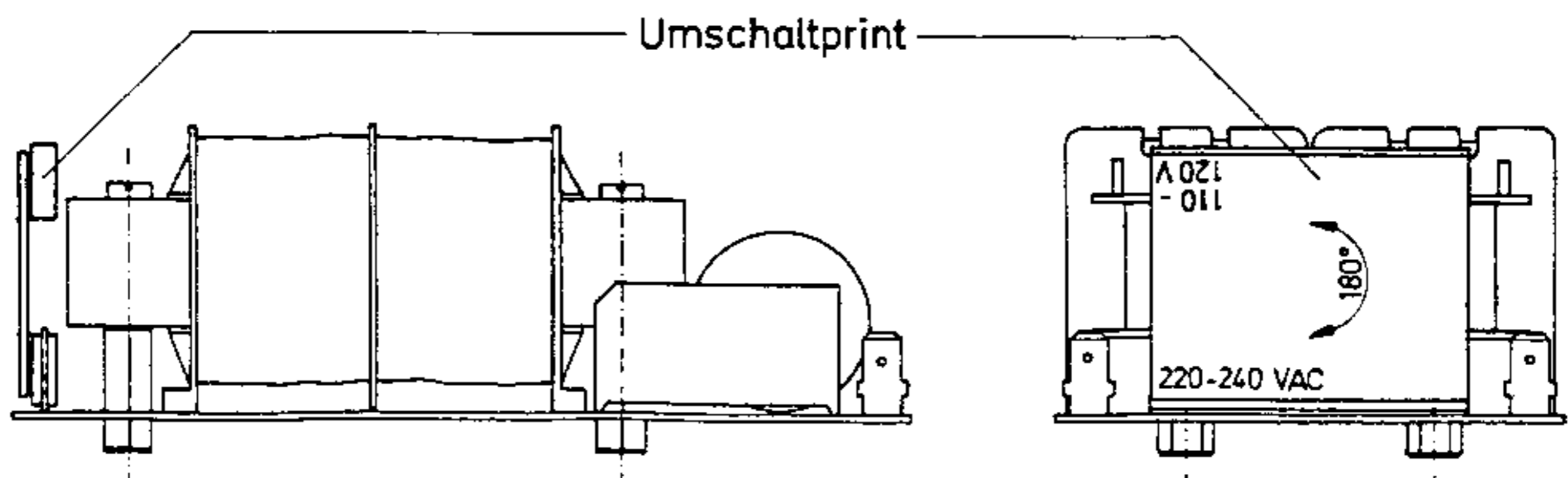

3.1.6 DISPLAY

Shutter travel limits can be monitored by means of two LED's on the front panel of the control box. One signals "RESET" and the other enable ("READY"). On the processor card are 5 additional LED's by which other functions may be monitored: Supply voltage, reset, pulse, direction and enable (see also page 10).

3.2 THE SHUTTER

The grey scale glass is held in a plastic track and is linked to the motor with a expansion-proof timing belt. The grey scale glass wedges travel counter to each another.

The motor is a 5 - phase stepper motor and operates at 2000 steps per revolution; which translates to 0.18 degrees per step. This further translates to 0.025mm of glass travel per step. With this high resolution the glass movement is free of jerks and precise positioning is possible.

To ensure the "repeatability" of positioning the grey scale glass wedges, a sensor card is installed on the guide rails. When activated the shutter moves to the appropriate position after reset. A limit switch prevents the glass plates from exceeding their limit.

On the shutter itself there are no operational controls. These are connected to the control box with two 1.5mm long cables (a 14 pole cable for the signals and a power cable for the fan).

4. COMPONENTS AS DELIVERED

1. Dimming Shutter G405 / PCS for grey scale glass wedges 205 x 220 mm
2. Transport Cover
3. Outrigger hangers for guide rails G405/27 235mm long
-(for use with objective lenses $f = 11 - 27\text{cm}$)..
4. Control box, for 110-120/220-240VAC, including clamp mount.
5. Operations Manual

4.1 ACCESSORIES

	<u>Order Code</u>
Interchangeable extension rails for Objective Lenses	
$f = 33,40,80,125\text{cm}$	G405 / 40
$f = 50\text{cm}$	G405 / 50
$f = 60\text{cm}$	G405 / 60
Ventilator Fan for Wide Angle Objective Lenses	G409 / PCS

5. OPERATING INSTRUCTIONS

5.1 MOUNTING THE UNIT ON THE PROJECTOR

1. Loosen the wing nuts on the front of the projector as much as possible and mount the objective lens.
2. Position the upper wing nuts vertically.
3. Mount the dimming shutter in the same manner as the objective lens corresponding to the guide rails in the support bolts.
4. Tighten the four wing nuts and secure both the shutter and the objective lens to the projector.
5. Secure the control box to the projector with the mounting clamp.

ATTENTION: Only for 18cm objective lens

Distance between gray scale glasses and objective front lens must be a minimum of 80mm!

5.1.1 CHANGING THE EXTENSION GUIDE RAILS

1. Remove the two front bolts M10 (SW19) and remove the shutter from the rails (8).
2. Remove the two fluted bolts (7) and draw the rails (8) out of the mounting brackets (1).
3. Take the brass glide nuts out of the guide rails and place them into the new rails.
4. Insert the new guide rails into the shutter support and replace the two fluted bolts.
5. With the M10 bolts, mount the shutter on the new guide rails (8).

FOR NUMBER LOCATIONS SEE PAGE 4

5.2 ELECTRICAL HOOK-UP

Located on each projector are 3 - 4 pole Amphenol connectors, to which the control box may be connected. When the ON ("EIN") push-button on the projector ballast is pressed, the control box is supplied with power and the reset is engaged. The "RESET" LED (8) is illuminated. After reset is completed the shutter is enabled and the "READY" LED is illuminated. The shutter may now be operated by either INTERNAL or EXTERNAL control.

5.2.1 INTERNAL CONTROL

Located on the front panel of the control box are a potentiometer (5) and a mode selector switch (6). When the switch is in the "INTERN" position, the shutter is operated directly by the potentiometer.

5.2.2 EXTERNAL CONTROL

When the mode selector switch is in the "EXTERN" position, the shutter may be operated remotely by two methods.

FOR NUMBER LOCATIONS SEE PAGE 4

a.) ANALOG CONTROL 0 -10 VDC

The control signal (0 - 10 VDC) is supplied to the shutter from a lighting console to a 3 pole XLR connector installed in the front panel.

Switching between positive and negative control voltage (polarity of the signal) is not necessary.

Pin Configuration

- 1+3 Control Input, 0 - 10 VDC
- 2 Common

In this same manner, feed through control of the PANI slide changer "AMD 15" can be achieved (Control Cable G1534, Length 1.5 m).

Digital information (DMX 512) from a circuit in the "AMD 15" is transformed into a 0 - 10 VDC control voltage and connected with a 3 pole XLR connector

Pin Configuration

- 1 - NC
- 2 - Common
- 3 - Control Voltage

b.) AC CONTROL 0 - 110/220VAC

This method is used when control comes from regulated (dimmer output) voltage 0 - 110 or 220 VAC (No switching is required) The clipped sinus voltage is transformed to direct current using an AC/DC converter. This method of signal transformation has the advantage that power voltage fluctuation has no influence on the DC voltage on the motion of the grey scale glass.

5.3 Curve Selector Switch Set-Up: S1

With the aid of an 8 - pole hook switch S1 on the processor card, dampening (hysteresis), null point setting, and desired dimmer correction curve may be selected. The individual contacts of the switch designated S1-0 through S1-7 and are subdivided in accordance with the following:

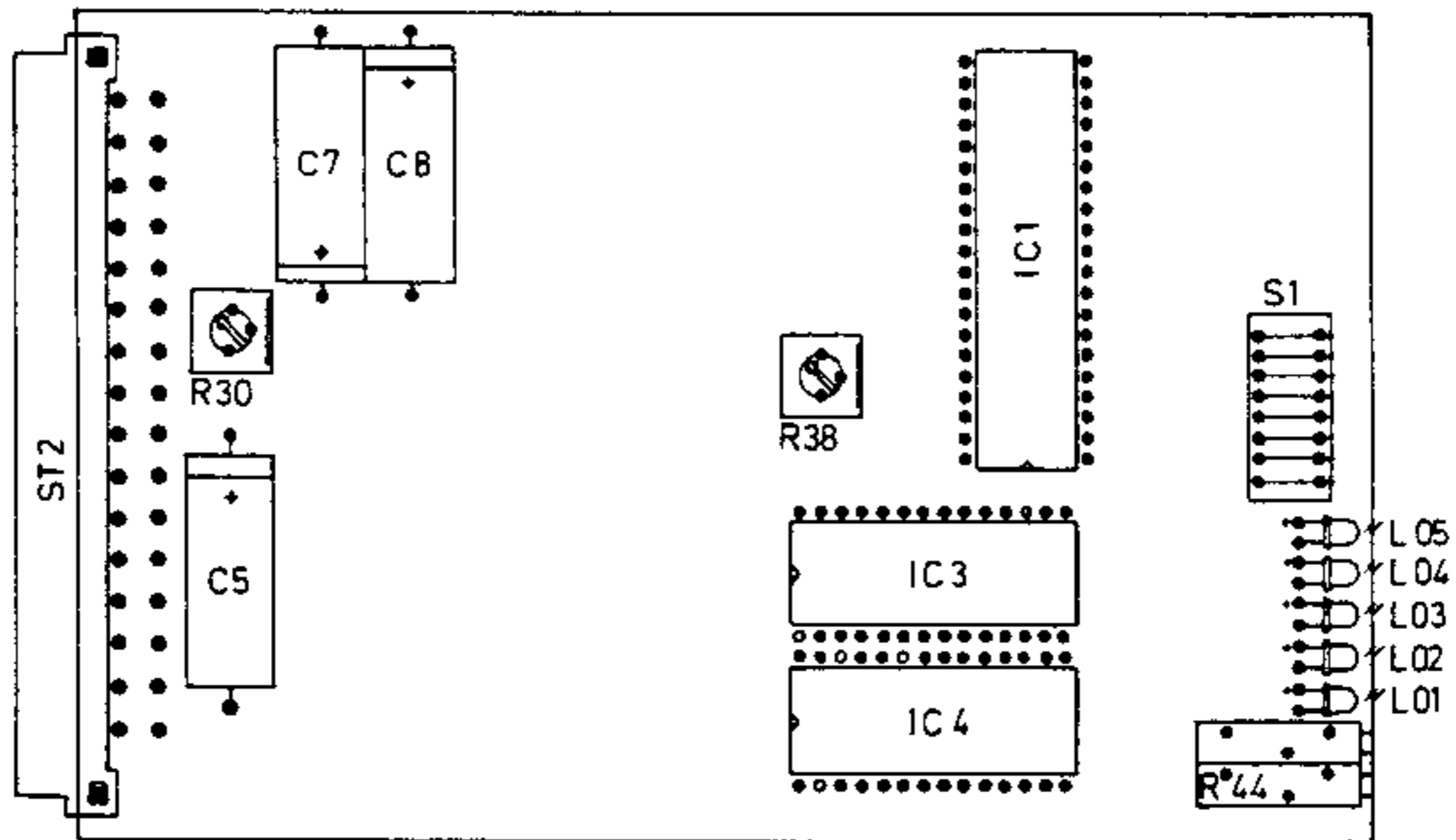

PROCESSOR CARD

IC 1	Microprocessor
IC 2	EPROM
R30	INTERNAL End Position Adjustment Trim Potentiometer
R38	Trim Potentiometer: Current Reference
R44	EXTERNAL End Position Adjustment Trim Potentiometer
LO1	"READY" LED
LO2	"DIRECTION" LED
LO3	"PULSE" LED
LO4	"RESET" LED
LO5	"POWER" LED
S1	Hook Switch

Group 1 (S1-0, S1-1):

This refers to an applied curve similar to the linearity of light response as perceived by the human eye. The following Table shows the four switch position possibilities.

	Linear	Curve 1	Curve 2	Linear
S1-0	0	1	0	1
S1-1	0	0	1	1

1 = Closed

0 = Opened

CURVE 1: In conjunction with a lighting control system with analog signals with a linear control voltage of 0 - 10 VDC.

CURVE 2: In conjunction with regulated dimmer output voltage of 0 - 220 VAC.

LINEAR: Without correction, without dampening. Regulation of control voltage affects the gray scale grey scale travel to a similar percentage (i.e. 10% of full control voltage moves the filters to 10% open and so on).

IMPORTANT: Correction curves 1 and 2 have a limited maximum value. Similarly with ramping control voltage, the "OPEN" position of the grey scale glass is never greater than this maximum value. However there is no limit of this maximum value in linear operation. This means it is possible with adjustment of the control box, to cause higher control voltages to allow the grey scale wedges to release the limit switch and cause the unit to RESET. In this case shuttle grey scale wedges between the reset mark and maximum position. In these instances the maximum value must be re-adjusted. (see section 6. Adjustment).

Group 2 (S1-2, S1-3, S1-4):

Even though the integrated circuit reduces control voltage fluctuation to eliminate shutter jerks, further measures are still necessary, namely Dampening (Hysteresis). This is an interval where control voltage fluctuation has still no influence on motor control. The width of the hysteresis is adjustable between 3 and 31 steps, which translates to 0.08mm to 0.8mm of travel.

These three hook switch contacts provide new adjustment flexibility in four steps.

Step	3	7	11	15	19	23	27	31
S1-2	0	1	0	1	0	1	0	1
S1-3	0	0	1	1	0	0	1	1
S1-4	0	0	0	0	1	1	1	1

A favorable adjustment with a value of 19 steps is provided and is achieved with the following switch settings:

FACTORY SETTINGS: These are the recommended settings.

S1-2 = "OFF"
 S1-3 = "OFF"
 S1-4 = "ON"

Group 3 (S1-5, S1-6, S1-7):

The correction curve produces shutter travel which at first increases as control voltage climbs. That is to say that with control at 0%, the shutters do not lay exactly over one another. This may be compensated for by selecting the appropriate switch position.

As with Group 2, there are 9 possible switch combinations, in one of 53 step increments.

Step	0	53	106	159	212	265	318	371
S1-5	0	1	0	1	0	1	0	1
S1-6	0	0	1	1	0	0	1	1
S1-7	0	0	0	0	1	1	1	1

This correction depends upon curve type. In most cases the following switch positions are sufficient.

FACTORY SETTINGS: These are the recommended settings.

S1-5 = "ON"
 S1-6 = "OFF"
 S1-7 = "OFF"

5.4 REPLACING THE GREY SCALE GLASS

1. Remove the shutter cover. This is accomplished by the removal of two flat head M4x6 screws located on the upper side.
2. Remove the flat head mounting screws (1) M4x6 from the upper guide rails.
3. Lightly loosen the mounting screw (2) and swing the guide rail away in the direction of the projection.
4. Change the glass plates (5). These are inserted in the molded plastic piece (4)

ATTENTION: The treated side of the glass must be facing the projector!

5. Swing the upper guide rail carefully over the glass and re-mount the rail and shutter cover.

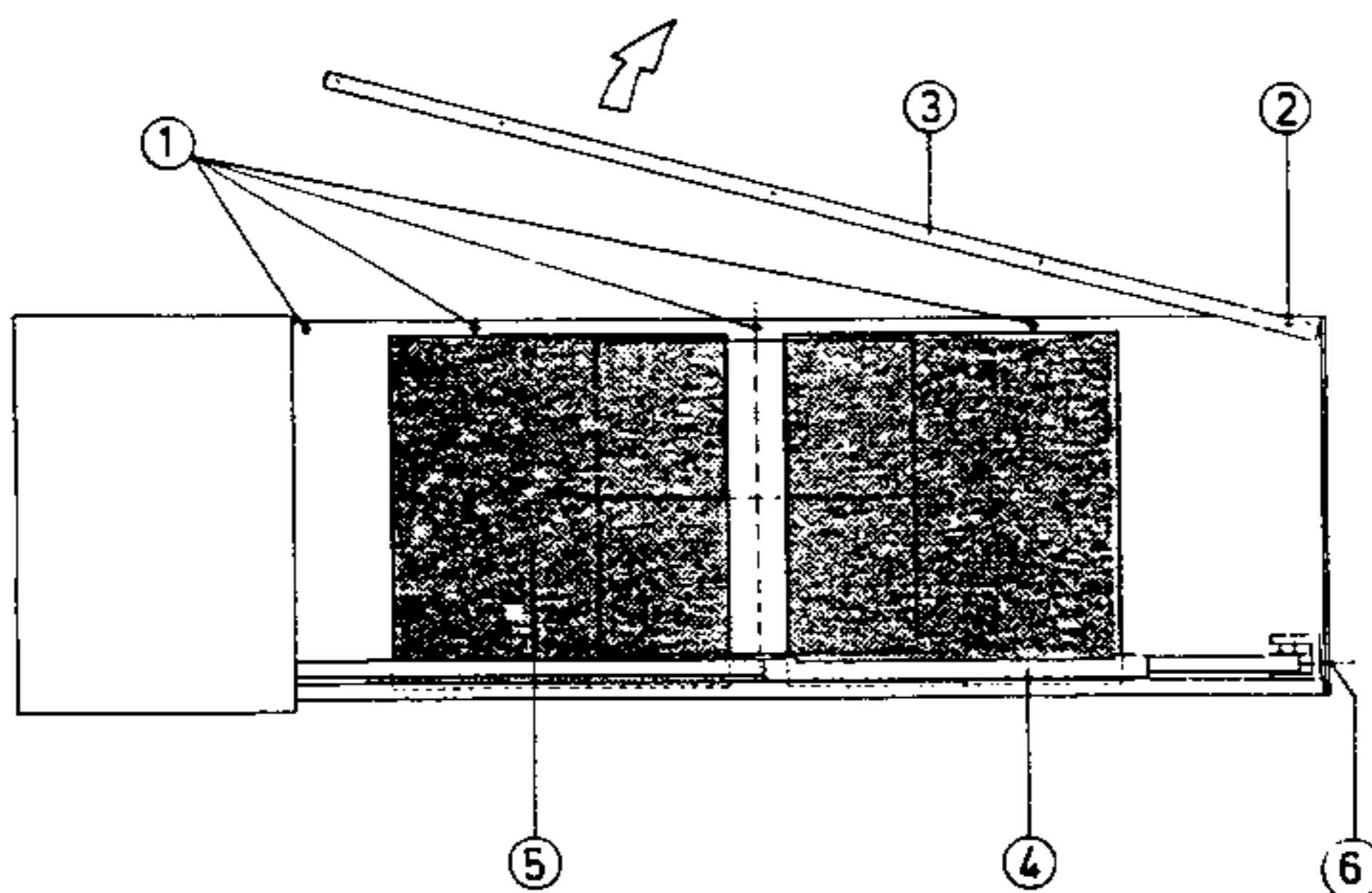

1. Mounting Screws
2. Mounting Screw
3. Guide Rails
4. Molded Plastic Piece
5. Grey Scale Glass
6. Timing Belt Tensioner

6. ADJUSTMENT INSTRUCTIONS

6.1 SHUTTER

The adjustment of the shutter is purely mechanical and factory set. It should not be necessary to make modifications to the basic set-up.

1. Remove the shutter cover (7) and housing cover (8).
2. **BELT TENSION.** With the screw located on the side (6) of the shutter, tension of the timing belt may be adjusted.

NOTE: The timing belt is not expandable and will not stretch.

3. **HOME ADJUST:**

The sensor card (10) is mounted on the guide rails with two screws (9). Sliding the card to the left or to the right will affect the null point position of the grey scale glass. Optimum position is factory set and lies near the center of travel.

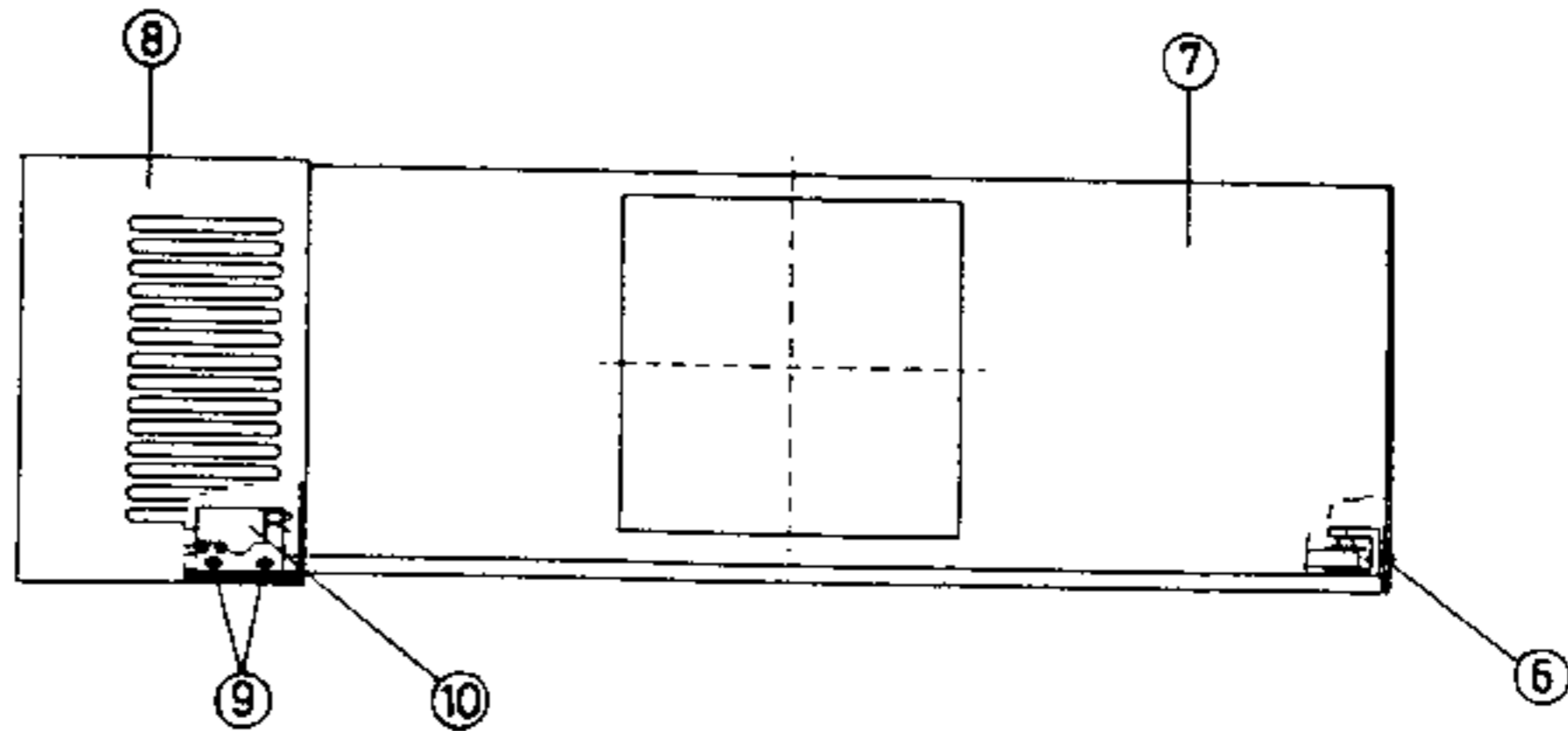

- 6. Timing Belt Tensioner
- 7. Shutter Cover
- 8. Motor Housing Cover
- 9. Sensor Card Adjustment Screw
- 10. Sensor Card

6.2 CONTROL BOX

6.2.1 ADJUSTMENT OF THE AC/DC CONVERTER(120/220VAC)

No power switching necessary

1. Connect control box to power source (projector)
2. Connect control input (the cable with connector) to a dimmer output circuit.
3. Connect a DC-voltmeter to ground and to the anode of diode D1 (MP 1).
4. Set dimmer to 0%. Adjust trim potentiometer R00 to 0VDC.
5. Set dimmer to 100%. Adjust trim potentiometer R12 to 10VDC.

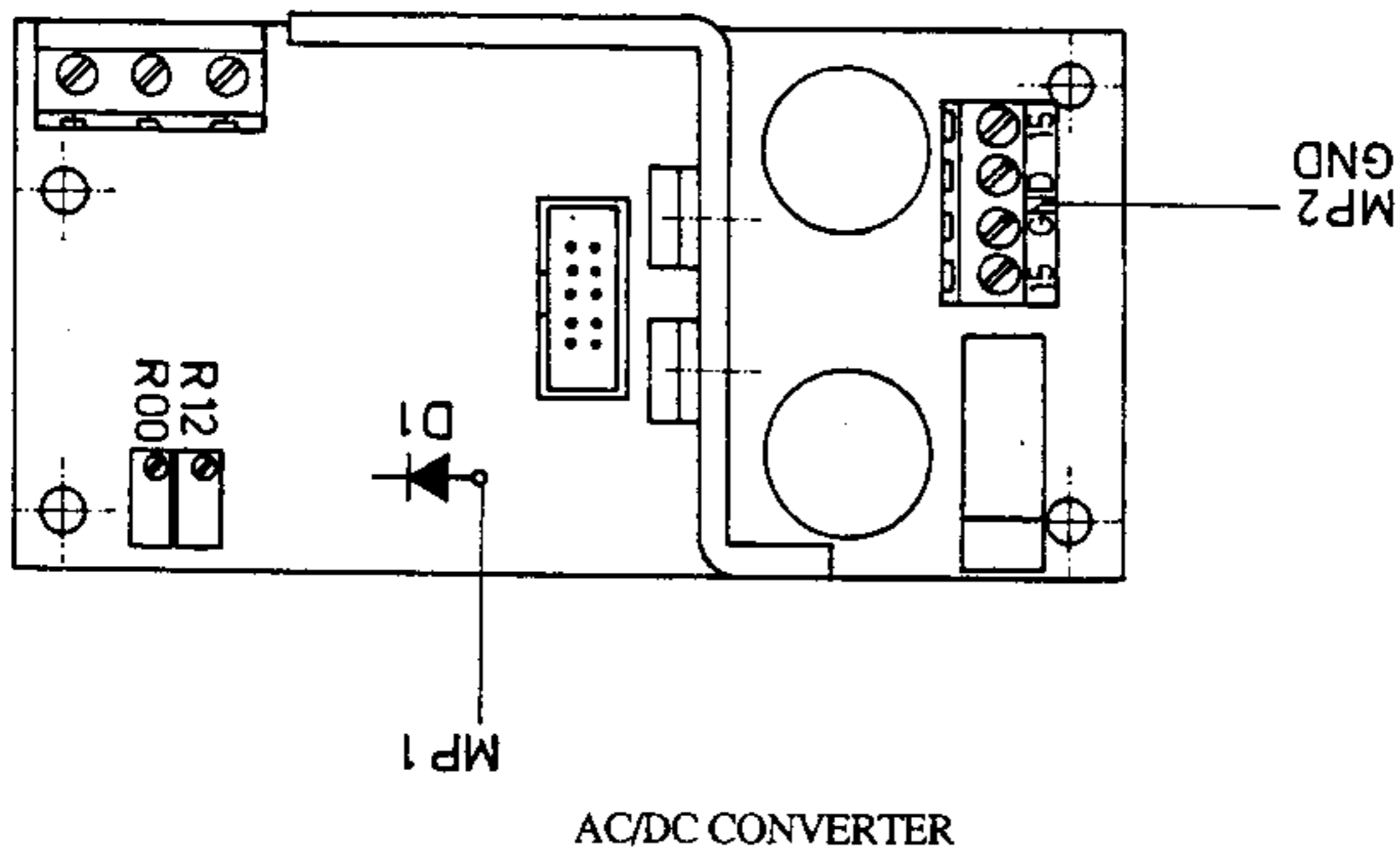

6.2.2 ADJUSTMENT OF THE PROCESSOR CARD

The following hook switch configuration should remain unchanged

S1 (2,3,4)	Dampening (Hysteresis)	Factory Setting	0 0 1
S2 (5,6,7)	Null Point Setting	Factory Setting	1 0 0

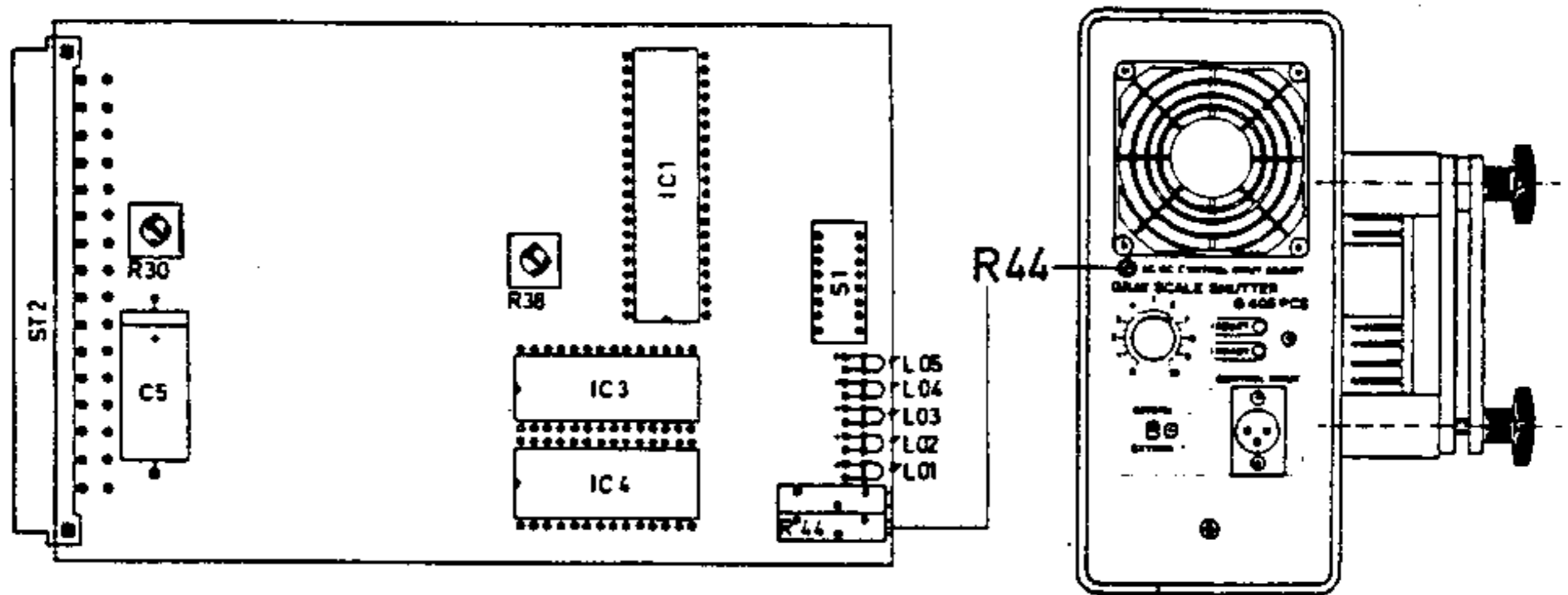

1. BASIC ADJUSTMENT

1. Unhook (disconnect) S1-0 and 1, (linear operation without table).
2. Open shutters.
3. Turn potentiometer R30 to it's approximate mid position. Turn R38 and open the shutters until the grey scale filters rest against the reset lever (limit switch).
4. Control the shutter's opening and closure with the potentiometer "INTERN".

This optimum adjustment is set at the factory by production control. This adjustment should not be required.

2. ADJUSTMENT OF INTERNAL CONTROL

1. Select internal mode
2. S1-0 Connect S1-0 or S1-1 depending upon desired curve 1 or 2.
3. Adjust R30 until the gray scale wedges reach their maximum open position.
(Do not over turn)

3. ADJUSTMENT OF EXTERNAL CONTROL

1. Select external mode
2. Set control voltage to 100%
3. Adjust R44 until the grey scale wedges reach their maximum open position.
(Do not over turn)

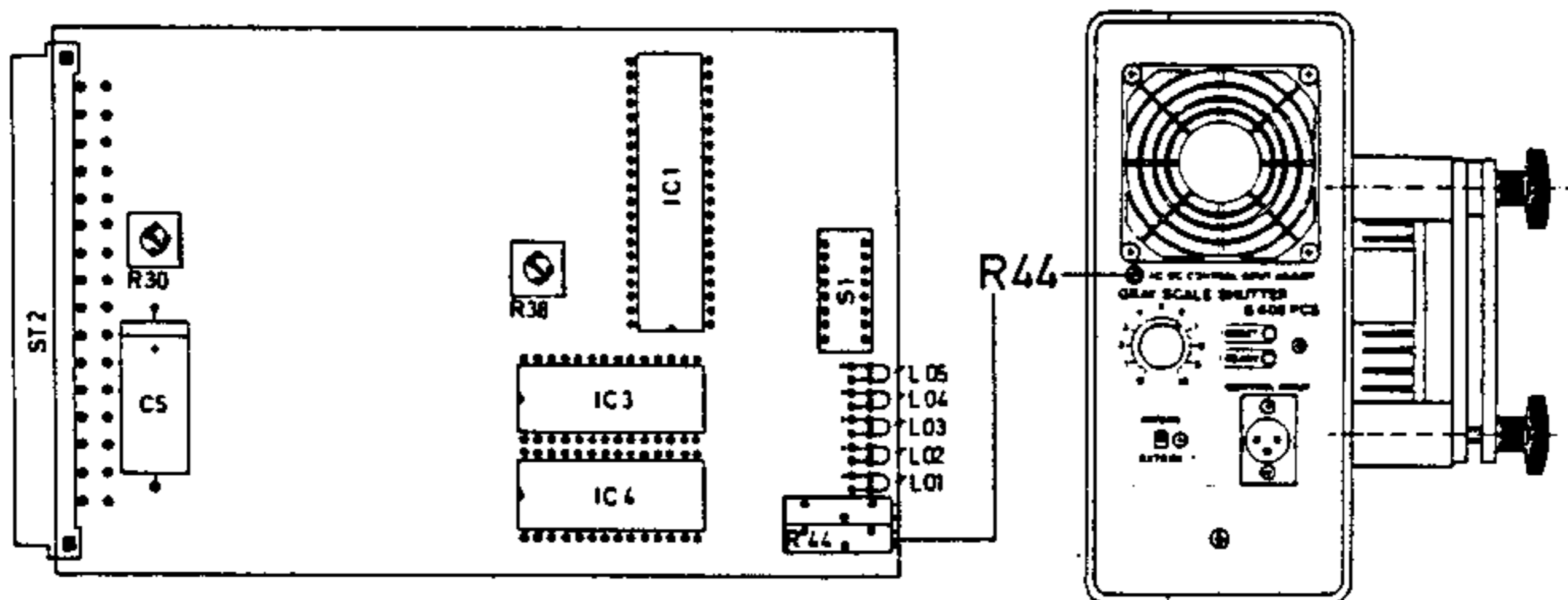

7. GENERAL TECHNICAL DATA

Weight Unpacked:

Dimming Shutter:	11 kg
Control Box:	7 kg

Weight Packaged:

Dimming Shutter and Control Box:	23 kg
Carton Dimensions:	88 x 38 x 34 cm

Protection Class: IP 20

Maximum Operating Temperature: 40°C

8. SPARE PARTS LIST

8.1 SHUTTER

	<u>Order Code</u>
Grey Scale Glass Filters (Wedges)	68-24-17
Grey Scale Guide	68-24-37
Grey Scale Supplements	68-24-38
Transport Cover	St3 0.7 215 x 247
Timing Belt	XL 037
Timing Belt Tensioner	68-24-09/11/FAG/XL
5-Phase Stepper Motor	12670
Directional Blower	68-24-30
Selastic - Vibration Mounts	21682 Form A
Sensor Card	BH 195 02 01
Clamp	68-24-35
Connector (Amphenol)	T 3108 001
Housing Casting	68-24-04
Fluted Grip Bolts	GN 6335.4-Sk-63-M10-20
Milled Screws	GN 421-M4-15
Milled Nuts	GN 420-M4
Splints	3.2 x 16 verz. DIN 94
End Spring Bracket	CE100F26-4 + EC100F-4C
Resistor Wire in Aluminum Housing	820R/50W

8.2 CONTROL BOX

	<u>Order Code</u>
Operation Print	68-34
Mother Board	68-35
AC/DC Converter	50-22
Processor Card	BH 195 01
Motor Control Card	D 631.01.RS02
Power Supply	68-25-18
Adjustment Pins	Mod. 8 L=100
Pressure Springs	Federdraht PN 1006/2
Flat Cable	171-16
Fuse Holder	FEU 31.1681
Cap	FEK 31.1663
Fuse	SP 001.1010 4A
Connector (Housing)	31.11.000
Cable Connector	T3108001
Heyko-Cover Cap	P250 8601 11
Fluted Grip Bolts	GN 6335.4SK-32-M6
AC Fan EBM	W2 S076 AA-01-03
Fan Guard EBM	92163-2-2929
Ventilator Grill	68-25-10
Clamp for Control Box	68-07-69
Clamp Spacers for Control Box	68-07-71
Grounding Screw	M4 x 20 DIN 965
Resistor Wire	1.2 k 50W
Resistor	15 k 5W

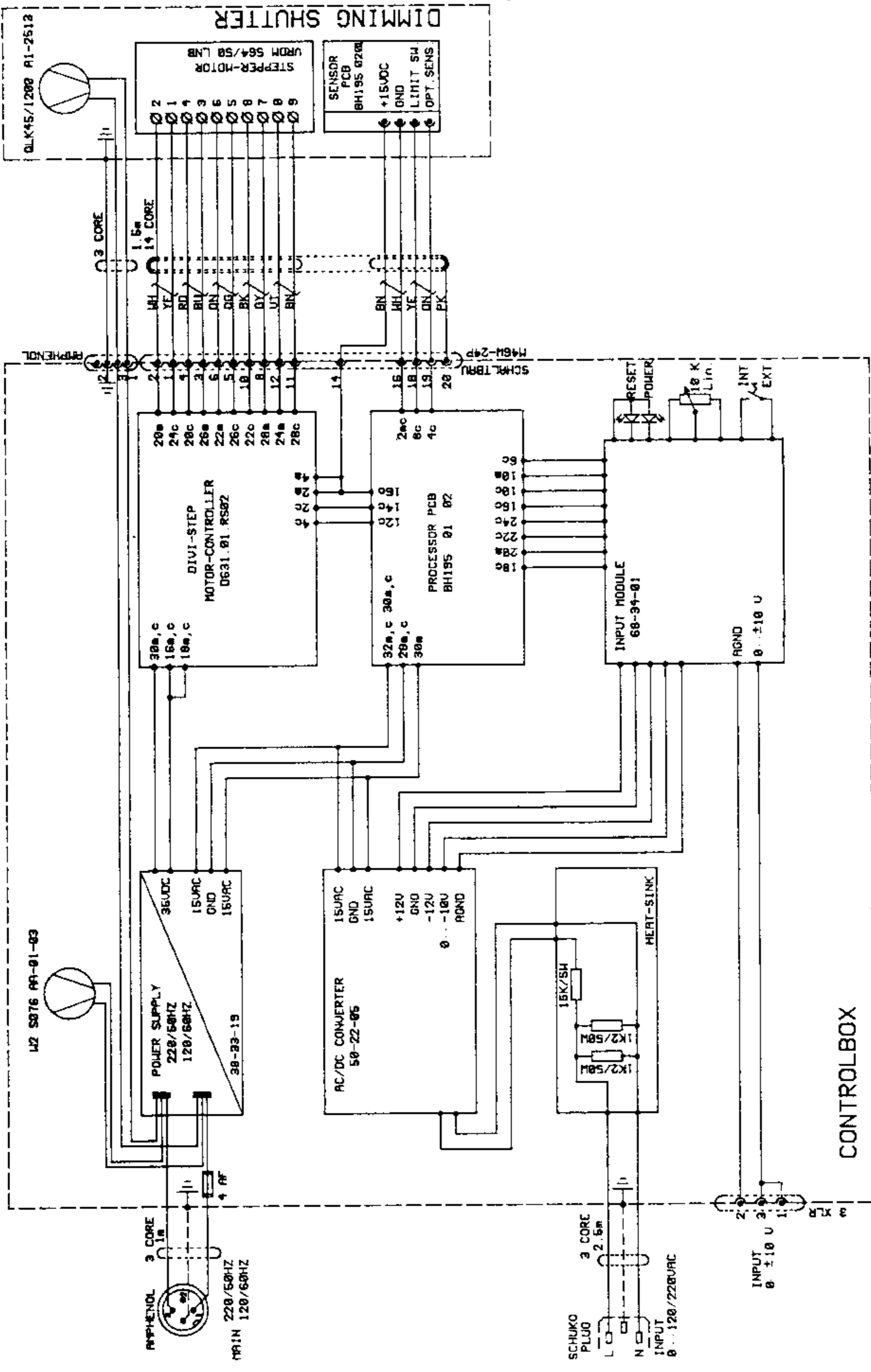

Date	07-01-92
DRAWN	DR.

GRAUKEILBLLENDE
GRAY SCALE SHUTTER
G 405 PCS

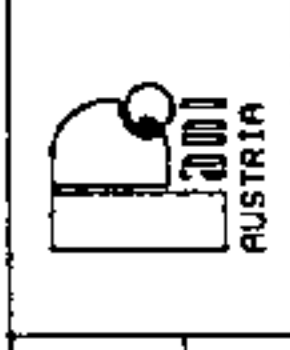

BLOCKDIAGRAM

CONTROLBOX

68-24-40

Assembly instruction

By mounting of the dimming shutter please take care, that the shutter is placed directly in the optical axis (shutter parallel to slide level, extension brackets parallel to direction of projection). Otherwise the "Black Out" won't be symmetrically on the whole projection-surface, but extended from one side to the other (curtain effect ?)

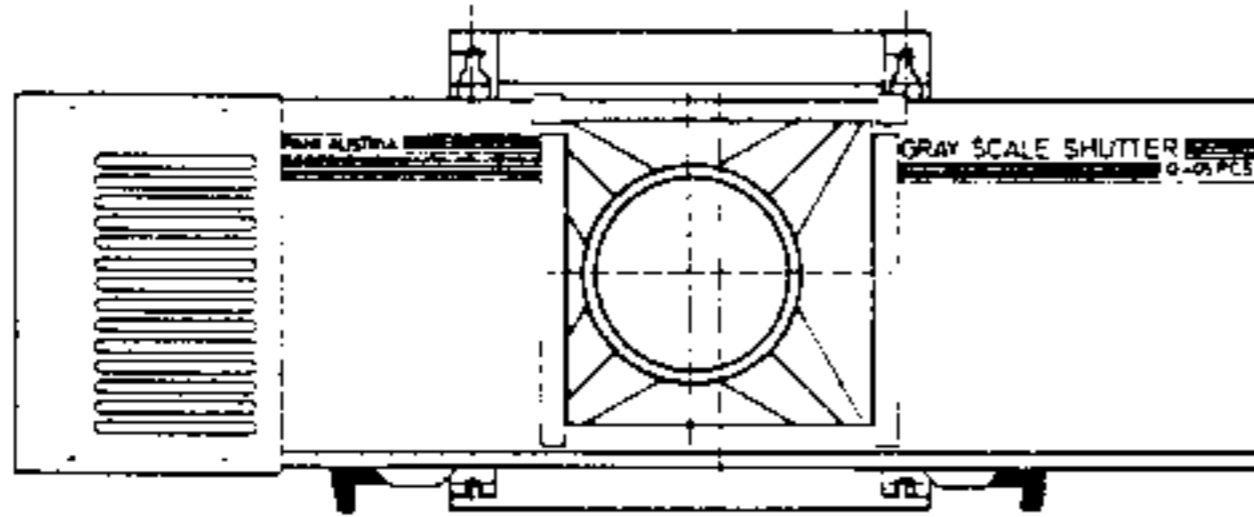

wrong

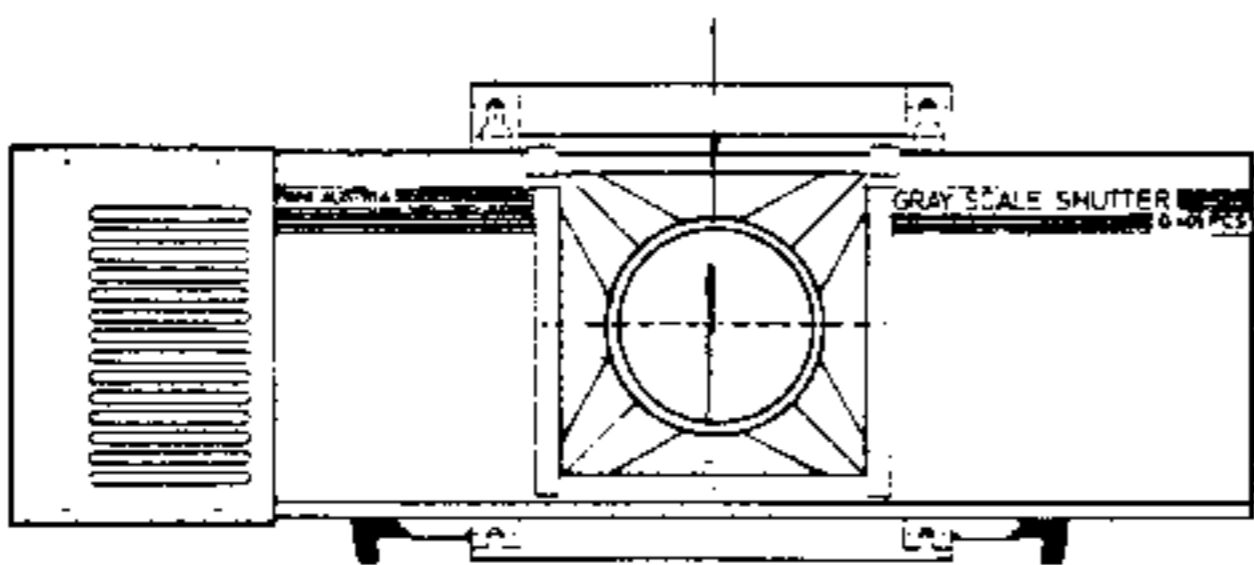
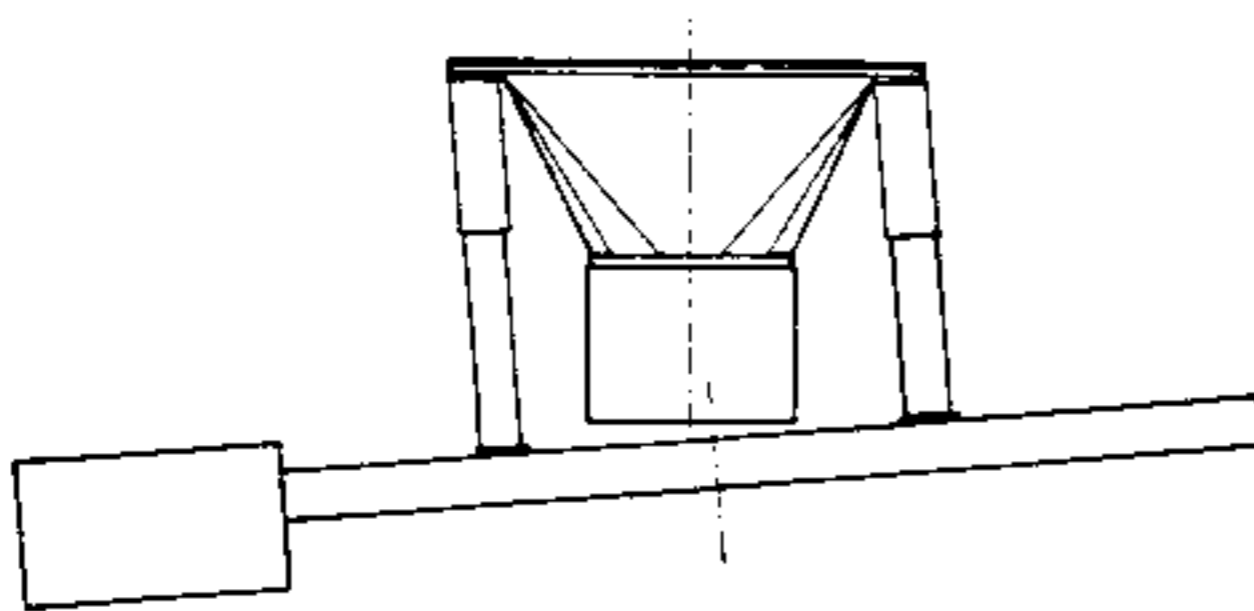

correct

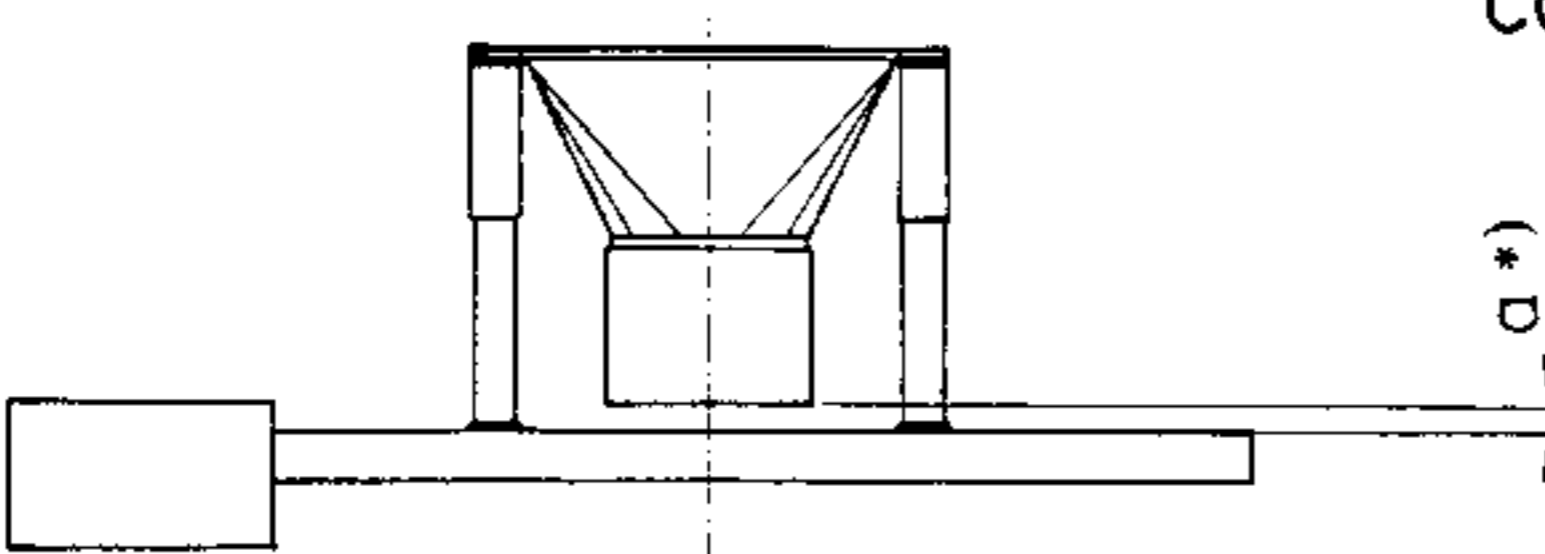

By use of several projectors (projector line) we recommend to insert the dimming shutter vertically.

***) CAUTION !**

By use of objective lens $f = 18$ cm, the distance must be at least 80 mm otherwise the temperature on the gray scale will be too high !